



SURVEYORVFT Pressurized
 Camera Dome Housing

- Sealed and pressurized housing offers maximum environmental protection
- Impact-resistant polycarbonate dome
- Provides indoor or outdoor environmental control for SurveyorVFT Camera Dome
- Pendant or wall mount available
- Versions available with color 22X or day/night 23X or 35X
- High-resolution in 23X and 35X models (540 TVL)
- Wide Dynamic Range (23X and 35X) provides best contrast for high quality images
- 23X provides Digital Noise Reduction and enhanced sensitivity
- Enhanced autofocus
- EIS (image stabilizer) on 35X model
- Prefabricated multi-conductor cable assembly available
- Compatible with all Vicon matrix systems
- Low pressure sensor alarm output
- On-screen temperature, humidity and pressure value indications
- Daisy chain connectivity with full duplex capability
- ViconNet (Version 5) (TCP/IP) converts to digital video for viewing and control on Kollector Elite and Pro Digital Video Recorders and ViconNet workstations
- Fiber-optic option transmits video and control data to fiber optic receivers over long distances
- UTP option transmits video up to 3000 ft over unshielded twisted pair
- NEMA TS2 compliant

The SurveyorVFT Pressurized Camera Dome housing has all the features and functions of the SurveyorVFT Camera Dome System. The interior is pressurized with dry nitrogen gas and regulated with a relief valve. A "Low Pressure Warning" displays if pressure inside the dome dips below ½ psig. Sensor titles display for temperature, relative humidity and pressure, which can be disabled. In addition, the interior is environmentally controlled using a thermostatically-controlled heater/fan assembly. This environment is characterized as ideal (IP67 rated) and provides the maximum protection against the elements that would normally cause rapid deterioration of electronic and video components. The exterior is UV resistant polyethylene plastic. The lower dome is injection molded distortion-free clear polycarbonate plastic. The SVFT-PRS can be programmed and operated using any Pilot or NOVA™ control system and enhanced Vicoax@ll protocol. It is available for outdoor use and can be configured with a variety of camera types. Refer to Table 1 for models.

The basic SVFT-PRS provides video transmission over coaxial cable. Options are available that provide TCP/IP (ViconNet), fiber-optic and twisted-pair (UTP) video transmission. Each of these options includes an interface board that allows the specific type of video transmission. An appropriate receiver is required.

The ViconNet® (version 5) option provides support for network connection to Kollector® Elite Digital Video Recorders and ViconNet Workstations via ViconNet software. A pre-installed Network interface board allows direct plug-in to a system network switch. Video from the camera is available to all network recorders and workstations for live view and recording.

The SVFT-PRS camera dome can be used in conjunction with competitive PTZ drivers through DIP-switch selection.

The SVFT-PRS is designed for easy snap-in installation. The drive simply snaps into the housing. When removed, the housing retains all programmed functions in its on-board non-volatile memory. The customer interface board snaps down for easy access. The customer interface board is pre-wired for convenience.

There is a wall mount and pipe adapter available for mounting the pressurized housing.

ASSOCIATED EQUIPMENT AND ACCESSORIES

Model SVFT-PR-WMA Wall Mount, Product Code 8381-01: Used to easily mount the pressurized housing to a horizontal surface for an indoor or outdoor application. A convenient access door allows installation and servicing. Refer to Product Specification 144.

Model SVFT-PR-P Pipe Adapter, Product Code 8382: Used to easily mount the pressurized housing to various SurveyorVFT mounts or a vertically oriented 1 -1/2 inch NPT schedule 40 pipe. Refer to Product Specification 144.

Model SVFT-PRC12 Pre-Wired Coaxial Cable, Product Code 8739: Prefabricated coaxial cable for all connections.

Model SVFT-PRC12T Pre-Wired Twisted Pair Cable, Product Code 8740: Prefabricated twisted pair cable for all connections.

Vicon Product Facts		Model No: SurveyorVFT Pressurized	Product Code: See Table 1	SEC: 3	SPEC: V163	REV: 509
----------------------------	--	---	------------------------------	--------	---------------	----------

Product Specification

Model Number	Product Code	Camera Type/Format	Optical Zoom/Total Zoom
SVFT-PRS22E	8768	Color/NTSC with ExView Technology	22x/264x
SVFT-PRS22EC	8768-01	Color/PAL with ExView Technology	22x/264x
SVFT-PRS23	8769	Color/NTSC (day/night with WDR and DNR)	23x/276x
SVFT-PRS23C	8769-01	Color/PAL (day/night with WDR and DNR)	23x/276x
SVFT-PRS35	9103	Color/NTSC (day/night with wide dynamic range and image stabilization)	35x/420x
SVFT-PRS35C	9103-01	Color/PAL (day/night with wide dynamic range and image stabilization)	35x/420x

For ViconNet version 5 option, add -75 (-76 PAL) to the product code; Fiber Optic option, add -30 (-31 PAL) to the product code; for UTP (T) option, add -40 (-41 PAL) to the product code.

Table 1: SurveyorVFT Pressurized Model Versions

Model Number	Product Code	Description
VF-1400R	8421-00	Receiver, for SurveyorVFT transmission, simplex video and duplexRS-422 data
VF-1400RR	8421-02	Receiver, for SurveyorVFT transmission, simplex video and duplexRS-422 data
VF-SR-20/2	8423-00	Card cage with power supply

Table 1 (cont'd): Fiber Optic Receiver Options

Model Number	Product Code	Description
V-VID-BAL	6518-20	Transceiver, converts UTP video to composite, transmits or receives video and Vicoax data up to 1000 ft over twisted pair cable
V652R-NVT	7453	Receiver, converts UTP video to composite up to 3000 ft from transmitter (does not support Vicoax systems)
V1613-NVT	7648	16-Channel Hub Receiver, converts UTP video to composite up to 1000 ft from each transmitter
V1662-NVT	6519	16-Channel Hub Receiver, converts UTP video to composite up to 3000 ft from each transmitter (does not support Vicoax systems)

Table 1 (cont'd): UTP Receiver Options

Model Number	Product Code	Description
S24WPS-1	7028-10	Single-channel, indoor/outdoor, 120 VAC input, 24 VAC output, 2 A
S24PS-230	7027-01	Single-channel, indoor, 230 VAC input, 24 VAC output, 2.5 A
S28WPS-1/ S28WPS-230	7030-10/7030-01	Single-channel, 120/230 VAC input, 28 VAC output, 3 amps, for outdoor SurveyorVFT Camera Domes
V2448-175PS	6410-20	Four-channel, indoor, 120 VAC input, 24/28 VAC output (jumper selectable), 7/6.25 amps (total), for indoor SurveyorVFT Camera Domes
V248-600PS	8438	Eight channel, 120 VAC input, 24 VAC output, 25 amps (total), for indoor SurveyorVFT Camera Domes
V248-300PS	6422-10	Eight channel, 120 VAC input, 24/28 VAC output, 12.5/10 amps (total), for indoor SurveyorVFT Camera Domes
V2416-600PS	8437	Sixteen channel, 120 VAC input, 28 VAC output, 26 amps (total), for indoor SurveyorVFT Camera Domes

Caution: Be aware that some of these power supplies are for indoor use only. Also note that on multi-channel units, the amperage stated is the total for all channels. To be assured of adequate current for the installation, in some cases, this means that not all channels can be used.

Table 1 (cont'd): Power Supplies

Note on Competitive Protocols: All companies make changes and improvements in their products. Because this product can interface with equipment not manufactured by Vicon, there is a possibility that the interface protocols may have changed since Vicon tested this product with the interfacing equipment. Vicon recommends purchasing a single unit for bench testing prior to purchasing and installing this product in quantity.

The Vicon SurveyorVFT™ is designed to store PTZ preset locations on the internal memory. Certain manufacturers' controllers are designed to store PTZ preset locations in the controller. Therefore preset functionality in the Vicon dome will not work correctly with these types of controllers.

ELECTRICAL

Drive Type: Electrical motorized pan and tilt with electronic control.

Camera Types: Units available in color and day/night (NTSC/PAL) formats and a variety of zoom and feature capabilities.

Input Voltage: 18-30 VAC. Will operate within spec on voltages up to 32 VAC. For voltages between 30-32 VAC, use a Class 3 indoor/dry or outdoor/wet power supply.)

Current: 1.8 A with SurveyorVFT (coax, UTP, fiber); 2.3 A (ViconNet).

Power Consumption: 44 W with SurveyorVFT (coax, UTP, fiber); 54 W (ViconNet).

Heat Equivalent: 2.5 btu/min (0.6 kg-cal/min) with SurveyorVFT (coax, UTP, fiber); 3.1 btu/min (0.77 kg-cal/min) (ViconNet).
Note: These figures represent the conversion of 100% of the electrical energy to heat. Actual percentage of heat generated will be less and will vary from product to product. These figures are provided as an aid in determining the extent of cooling required for an installation.

Maximum Power Cable Distance: See Table 2.

Camera Mechanism Connector Types: Video Out: See version type. Power: 2-position removable screw terminal block. Control Input/Output: See version type. Relay Output: See version type. Alarm Input: 8-position removable screw terminal block.

Housing Connector Type: 23-pin, circular, pressure rated. Mating connector included for access to all SurveyorVFT signals including heater/blower, power, communications and video.

Video Output

Impedance: 75 ohms.

Fuse: F1: 5x20 mm, 1.6 A 250 VAC, slo blo.
 F2: 5x20 mm, 2.5 A 250 VAC, slo blo.

Radio Frequency Emission Rating: FCC Class A.

MECHANICAL

Application: Indoor or outdoor.

Mounting: Wall mounting with SVFT-PR-WMA Wall Mount or pendant mounting with SVFT-PR-P Pipe Mount.

Seal Type: 1 "O" ring, fabricated from neoprene, 0.139 in. (3.5 mm) cord diameter and an EPDM (rubber) gasket.

Mount Size/Thread: 4 threaded hole pattern (3.75 in./95 mm square) on top used for mount attachment. Each threaded hole is 1/4-20 x 0.41 in. (10 mm) deep. Gasket provided to seal top interface.

Dimensions: See Figure. Pendant
 Housing Diameter (D1): 9.5 in. (241 mm).
 Dome Diameter (D2): 6.0 in. (152 mm).
 Housing Height (H1): 7.3 in. (185 mm).
 Total Height (H2): 10.2 in. (259 mm).

Weight: 7.5 lb (3.4 kg).
 12.0 lb (5.4 kg) with SurveyorVFT included.

Construction: Plastic, cast aluminum; trim ring, cast zinc/aluminum.

Color: White housing and sunshield; black trim ring.

IP Rating: IP67.

Table 2: Maximum Power Cable Distance

Wire Size (AWG) Annealed Copper Wire	Distance ft (m)			
	24 VAC		28 VAC	
	Coax, Fiber, UTP	ViconNet	Coax, Fiber, UTP	ViconNet
20	165 (65)	130 (40)	280 (85)	217 (66)
18	258 (102)	203 (62)	438 (134)	340 (104)
16	413 (126)	325 (99)	700 (213)	544 (169)
14	660 (262)	520 (159)	1120 (341)	870 (265)
12	1031 (314)	812 (248)	1750 (533)	1359 (414)

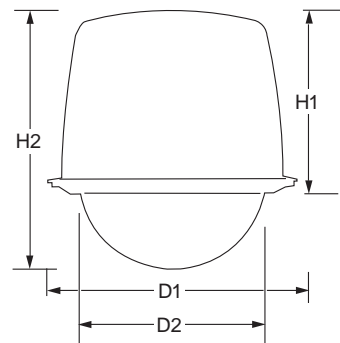

Shipping Dimensions: Height: 12.4 in (315 mm).
Width: 15.25 in. (387 mm).
Depth: 20.75 in. (527 mm).

Shipping Weight: 16 lb (7.3 kg).

Shipping Volume: 2.3 ft³ (0.07 m³).

ENVIRONMENTAL

Ambient Temperature and Humidity Range:

-30° F (-34° C) to 165° F (74° C) in accordance with NEMA 2.1.5.1 STD2; -40 to 132°F (-40 to 55°C) continuous rotation. Up to 100% relative humidity, condensing.

Maintained Temperature and Humidity Range:

14° F (-10° C) to 140° F (60° C) maximum. Up to 90% relative, noncondensing.

Ingress Protection: EN60529, IP 67 rated.

NEMA TSA Compliance:

Operating Voltage/Frequency: 2.1.2, 2.1.3;
Power Interruption: 2.1.4;
Temperature & Humidity: 2.1.5;
Transients, Power Service: 2.1.6;
Transients, Input/Output Terminals: 2.1.7;
Non Destruct Transient Immunity: 2.1.8;
Vibration: 2.1.9;
Shock (Impact): 2.1.10.

Wind: Tested at sustained winds up to 120 mph with gusts to 150 mph.

HOUSING OPERATION

Pressurization: Schraeder type valve used to fill and drain housing with dry nitrogen gas. Relief valve automatically relieves pressure at 5- 7 psi (0.34-0.48 atm). Leakage <2 psi per year.

Operating Pressure: 1 - 5 psi (0.07 - 0.34 atm or bars) maximum.

Pressurization Volume: 0.28 ft³ (0.008 m³) volume.

Low Pressure Indication:

By default, if pressure dips below 1/2 psig a "Low Pressure Warning." On Screen Display message appears. This alarm warning may also be sent to the CPU by enabling the alarm in the dome's **Alarm Handling, Report Enable** sub-menu. When this is activated, the On Screen message will not appear. The unit is preconfigured for sensor titles to display for temperature, relative humidity and pressure. These titles can be disabled in the titling menus.

Surge Protection: Video level is clamped at 6.5 V max. Power protected to 1500 W peak pulse with a 10/1000 µs waveform. RS-422 data lines are clamped to 5 V max. with transient suppressors.

CAMERA MECHANISM OPERATION

Video Pan View: 360°.

Video Tilt View: -2.5° (-2.5° above horizon) to 92.5° (-2.5° past vertical).

Pan Speed: Variable, 0.1 to 360°/sec.

Autopan Speed: Variable, 0.1 to 42°/sec; enable/disable.

Tilt Speed: Variable, 0.1 to 150°/sec.

Zoom and Focus Speed: Less than 1.8 sec from end to end.

Sectoring: 16 max, programmable for size and titling; capability to be blanked out.

Preset Capabilities: 79 individual programmable preset positions.

Preset Solving Speed: 1 sec nominal.

Preset Accuracy (Pan & Tilt): 0.1° maximum.

Tour Capabilities: 8 tours. 32 programmable events per tour. Events may be preset positions with speed control, alarm acknowledge, dwelltime control, relay control, call autotours, tour repeat or another tour, save/recall camera status.

Autotour Capabilities: 2 autotours available with 256 pan, tilt and zoom functions per autotour. Programming is done in real time with joystick and push buttons.

Alarm Capabilities: 4 alarm inputs, individually programmable. Functional state enable/disable. Report state (report on/off). Active state (high/low). Mode (manual, momentary or automatic) with programmable dwell time control. Set and reset action (preset solve, relay on/off, tour, autotour. Alarm titling.

Relay Output Capabilities: 1 relay output. Power-on state definition (on/off). Output type definition (momentary or latching). Relay function status titling. Resistive Load: 1.5 A @ 30 VDC. Inductive Load: 0.75 A @ 30 VDC.

Control Display: On-screen, menu-driven system allowing full configuration of the dome.

Privacy Masks: 16 individual, programmable, zoom-scalable.

Screen Titling Capabilities: Variety of camera ID information is software programmable. Programmable for camera, preset, sector, relay and alarms. Camera: 1 for each. Preset: 79 maximum. Sector: 16 maximum. Alarm: 4 maximum. Individual type date and time enable/disable; 20 characters maximum. Selectable position. Three text sizes for top 2 lines. Fade capability. Compass/azimuth, 8 compass headings (N, NE, E, SE, S, SW, W, NW). Diagnostic information can be displayed onscreen.

Scheduling: Real time clock allows scheduling of up to 64 events, including presets, relays, alarms, tours or autotours.

Multilanguage Menu: English, Spanish, French, German and Italian.

Day/Night (23X/35X) Features: 6 programmable motion detection zones with 3 sensitivity levels; image freeze during preset solve; flip (invert) video image.

Auto Baud: Auto baud detection in RS-232/RS-485 mode; 4800, 9600, 19,200 bps baud rates supported.

Absolute Position Control: Available in RS-422/RS-485 mode. Pan/tilt: 0.125°; zoom: 0.125X.

PTZ Functions: Auto Home: Can program to go to a set home location after a set time duration of no activity or to its home upon power-up. Scalable PTZ: Can enable to adjust the pan and tilt speed relative to the amount of magnification. PTZ Route: Takes shortest distance to preset PTZ selection. Overload: Software control to prevent movement beyond limits. Lens Speed: Selectable Low, medium, high from control station. Iris Protection: Autoiris and auto shutter adjustment for amount of light.

Competitive Protocols: DIP switch selectable.

COAXIAL/UTP VERSIONS

Control Protocol Hardware: Vicon's Pilot/NOVA control systems and a variety of Vicon keypads.

Control Protocol Software: Vicon's Surveyor Direct Control program run on a standard PC type computer with an RS-422/485 half duplex protocol interface.

Control Protocol Format (selectable via DIP switch 2)*: Vicon: RS-422 or RS-485 protocol. Communication is simplex or half duplex operation at 4800, 9600 or 19,200 baud or Vicon's enhanced VicoaxII protocol (superimposed data on composite video signal) automatically detected upon power up. RS-485 protocol utilizes full tri-state outputs for daisy chain capability. Pelco: Pelco D Protocol (3/2/99); RS-485 N.8.1, simplex 2400 bps, duplex 4800 bps. Sensomatic/AD: RS-422/RS-485 communication protocols user's guide Rev. A (csd 05/00); RS-422/RS-485 duplex N.8.1 4800 bps. May require RS-422 converter, RCSN422. Ultrak: KD6, KD6-Z control protocols; RS-485 simplex E.8.1, 9600 bps. Philips: Receiver/Driver/Auto Dome control code protocol; RS-232 simplex N.8.1, 2400 or 9600 bps. Kalatel: Non-repeating transmit commands; RS-422 simplex N.8.1, 9600 bps. Cohu: MPC System RS-422 interface; RS-422 duplex N.8.1, 9600 bps. Panasonic: Panasonic conventional and new camera protocol.

NTCIP: 1205 v1.08 compliance.

*Note: All companies make changes and improvements in their products. Because this product can interface with equipment not manufactured by Vicon, there is a possibility that the interface protocols may have changed since Vicon tested this product with the interfacing equipment. Vicon recommends purchasing a single unit for bench testing prior to purchasing and installing this product in quantity.

Vicon Product Facts		Model No: SurveyorVFT Pressurized	Product Code: See Table 1	SEC: 3	SPEC: V163	REV: 509
----------------------------	---	--	-------------------------------------	---------------	----------------------	-----------------

Note: Pelco is a registered trademark of Pelco. Sensomatic is a registered trademark of Tyco International Limited. Philips/Bosch is a trademark of Koninklijke Philips Electronics N.V. Kalatel is a trademark of GE Interlogix. Ultrak is a trademark of Honeywell Inc. Cohu is a trademark of Cohu, Inc.

Connector Types: Video: Video Out:
Coax: BNC-F.
UTP: 3-position removable screw terminal block.
Control Input/Output: 3-position removable screw terminal block.
Relay Output: 8-position removable screw terminal block.

FIBER-OPTIC VERSION

Fiber Optic Receiver

Specs: I/O Level: 1 V p-p.
I/O Impedance: 75 ohms.
Bandwidth: 8 MHz.
Differential Gain: 5%.
Differential Phase: 5°.
SNR: 60dB.
Data:
Data Rate: Up to 19.2 Kbps.
Optical:
Wavelength: 850/1300 nm.
Loss Budget (62.5 u): 12 dB.
Connector: ST.

VICONNET VERSION (NETWORK/TCP/IP)

Connector Types: Video Out: ST type.
Control Input/Output: ST type.
Relay Output: 8-position removable screw terminal block.

Communication

Protocol Hardware: Vicon's Kollector Elite Digital Recorders and ViconNet Workstations.

Network Interface: 100 Mbps, TCP/IP Unicast.

Connector Types: Video Out: RJ-45 jack.
Network: Ethernet 100Base-T RJ-45 jack. 10/100 Mbps required for network connection.
Relay Output: 3-position removable screw terminal block.
Audio: 2 1/8-in. phono jacks.

SOFTWARE OPERATION (ViconNet)

Network Setup: Standard network protocol type using IP addressing scheme and separate PC application software.

Site Authorization: Camera can be setup using remote recorder or workstation GUI. Permissions can be assigned for macro create & edit, alarm setup, Authentication, Reports and System Status. Supports up to 20 Groups and 100 Users.

Macro Create & Edit: System macros can be configured to use the camera's video. In addition, within macros, alarms can be sent and remote macros run.

Alarm Setup: An alarm can be triggered on video motion detection and loss. The alarm can be sent to remote units.

Authentication: The video from the camera can be set to view the Authentication status symbol (A) on the displayed video.

Picture Quality and FPS Priority: Camera video can be setup to prioritize recorded picture quality and video FPS. Priority can be assigned to user/macro recording for highest requested video quality or Master user control.

CAMERA/LENS

Specifications: Refer to Table 3.

VIDEO TRANSMISSION

Maximum Distances: Coax: 1100 ft (350 m), cable dependant.
Vicoax: 1500 ft up to 140° F (60° C); 1000 ft up to 165° F (74° C). RG59.
UTP: up to 3000 ft (915 m), model dependant.
Fiber: 1 mile min.; longer distances available dependant on cable quality.

Technical Information

Specifications	Model Numbers		
	SVFT-PRS22E/ SVFT-PRS22EC	SVFT-PRS23/ SVFT-PRS23C	SVFT-PRS35/ SVFT-PRS35C
	Product Codes		
	8768-00/8768-01	8769-00/876901	9103-00/9103-01
	Formats		
	NTSC/PAL	NTSC/PAL	NTSC/PAL
Type	Color	Color	Color
Optical Zoom	22X	23X	35X
Digital Zoom	12X	12X	12X
Total Zoom	264X	276X	420X
Image Device	1/4-inch interline transfer CCD	1/4-inch interline transfer CCD	1/4-inch interline transfer CCD
Picture Elements	768(H) x 494 (V), 380,000 pixels/ 752(H) x 582 (V), 438,000 pixels	768(H) x 494 (V), 380,000 pixels/ 847(H) x 532 (V), 490,000 pixels	768(H) x 494 (V), 380,000 pixels/ 752(H) x 582 (V), 438,000 pixels
Scanning System	2:1 interlace, 525 lines 60 fields/sec/ 2:1 interlace, 625 lines 50 fields/sec	2:1 interlace, 525 lines 60 fields/sec/ 2:1 interlace, 625 lines 50 fields/sec	Progressive scan or 2:1 interlace, 525 lines 60 fields/sec/ 2:1 interlace, 625 lines 50 fields/sec
Sensitivity* (22EX/23X: at 40 IRE, f/1.6; 35X: at 35 IRE, f/1.4)	0.006 fc (0.06 lux), auto 1/4s 0.09 fc (1 lux), auto 1/60s (NTSC; 1/3s, 1/50s - PAL)	0.0009 fc (0.01 lux) auto 1/4s, IR OFF 0.009 fc (0.1 lux) auto 1/4s, IR ON 0.09 fc (1 lux) auto 1/60s, IR ON (NTSC; 1/3s, 1/50s - PAL)	0.000016 fc (0.00018 lux) auto 1/2s, IR OFF 0.003 fc (0.033 lux) auto 1/4s, IR ON 0.05 fc (0.5 lux) auto 1/60s, IR ON (NTSC; 1/1.5s, 1/50s - PAL)
Horizontal Resolution	470 TV lines (color)	540 TV lines (color)	540 TV lines
S/N Ratio	More than 50 dB	More than 50 dB	50 dB
Synchronization	Internal/External (line lock on AC line)	Internal/External (line lock on AC line)	Internal/External (line lock on AC line)
Automatic Gain Control (AGC)	Adjustable to 30 dB	Adjustable to 30 dB	Adjustable to 30 dB
Backlight Compensation	Software adjustable background video level	Software adjustable background video level	ON/OFF
Iris Control	Automatic/Manual	Automatic/Manual	Automatic/Manual
Wide Dynamic Range	N/A	OFF/ON (Auto or Manual)	OFF/ON (Auto or Manual)
Digital Noise Reduction	NA	Yes	NA
EIS (Image Stabilizer)	N/A	N/A	Yes (with digital zoom)
Video Focus	Automatic/Manual 1.0 m (tele) - 0.01 m (wide)	Automatic/Manual 1.0 m (tele) - 0.01 m (wide)	Automatic/Manual
White Balance	Automatic/Manual Red/Blue Gain Level	Automatic/Manual Red/Blue Gain Level	Automatic/Manual; Red/Blue Gain Level
Shutter Speed	Auto(DSS): 1/2-1/4000 Man: 1/2-1/30K sec	Auto(DSS): 1/2-1/60 Man: 1/2-1/30K sec	Auto(DSS): 1/2-1/4000 Man: 1/2-1/30K sec
Lenses			
Focal Length	4 - 88 mm	3.6 - 82.8 mm	3.4 - 119 mm
Aperture max	f/1.6	f/1.6	f/1.4
Horizontal Angle of View	47° wide, 2.2° tele	54° wide, 2.5° tele	55.8° wide, 1.7° tele

* For day/night cameras, IR ON is color mode; IR OFF is B&W mode

Table 3: Camera/Lens Specifications

VICON INDUSTRIES	89 Arkay Drive Hauppauge, NY 11788 www.vicon-cctv.com	TEL: 631-952-2288 FAX: 631-951-2288 TOLL FREE: 800-645-9116
-------------------------	---	---