



# PRODUCT SPECIFICATION

**MODELS:** V1300X-DVC, -RVC

**PRODUCT CODE:** REFER TO TABLE 1

**DESCRIPTION:** QUANTUM-TSI™ INTELLIGENT REMOTE CONTROL PANELS

The V1300X-DVC and V1300X-RVC are intelligent, multi-function, remote control panels. The V1300X series remote control panels are available in two versions. The V1300X-DVC is a desk-top control; the V1300X-RVC is rack-mounted. Refer to Figure 1.

**NOTE:** Throughout this specification sheet the terms "keypad" and remote control panel are used interchangeably. V1300X is used to refer to both keypads in the series unless specifically stated otherwise.

The V1300X keypad is front-panel programmable. The keypad/receiver communications baud rates, the operational mode of the keypad, keypad address, and passcodes can all be modified via the front panel.

<b>NOTES</b>	<b>SPEC NO.</b>	<b>REV.</b>	<b>SEC.</b>
	777	892	11



**V1300X-DVC QUANTUM-TSI INTELLIGENT REMOTE CONTROL PANELS**

The V1300X keypad features a pan-and-tilt joystick which can be set for variable- or fixed-speed operation. The keypad also offers pushbutton control for camera and monitor selection, zoom, focus, iris, autopan, autoiris, lens speed, receiver preset position entry, alarm acknowledgment, and receiver communication failure acknowledgment. The V1300X keypad features key input buffering for faster system response.

## CONTRACTORS' SPECIFICATION

### Remote Control Panel

The remote control panel (keypad) shall offer simple pushbutton control for the following CCVS functions: camera and monitor selection, zoom, focus, iris, autopan, autoiris, lens speed, receiver preset position entry, alarm acknowledgment, and receiver communication failure acknowledgment. The keypad shall feature key input buffering. The keypad shall have a joystick which can be set for variable- or fixed-speed operation to control camera receiver pan and tilt functions.

The following keypad parameters shall be front-panel programmable: the keypad/receiver communications baud rates, the operational mode of the keypad, keypad address, passcodes, speed control type, joystick response, receiver function inhibit, and automatic log off. The keypad shall offer two single keystroke and 18 double keystroke macro functions. Each macro shall be user programmable up to 256 keys.

The keypad shall use an Intel 8031 microcontroller. The system shall support three user-selectable modes of operation. In its different operating modes, the keypad shall be able to communicate directly with various CPUs, camera receivers, additional keypads, and matrix switchers.

The V1300X keypad shall perform the following self-diagnostic tests: LEDs and status displays, serial and parallel communications, reset circuits, front panel switches, memory ICs, and analog-to-digital converter.

The keypad shall be available in two versions: a desk-top control and a rack-mounted control. The rack-mounted keypad shall mount in a standard 19-inch EIA rack. The rack-mounted keypad shall have a swivel capability of 12... (i.e., the keypad may be tilted inside the rack at an angle of 12...).

The keypad shall be available in two operating voltages: 115 V, 50/60 Hz and 230 V, 50/60 Hz. The desk-top version of the keypad shall be supplied with a 10-12 VAC remote transformer. Maximum power consumption for the keypad shall not exceed 20 W.

The desk-top remote control panel (keypad) shall be Vicon model V1300X-DVC. The rack-mounted remote control panel (keypad) shall be Vicon model V1300X-RVC.

Product specifications subject to change without notice.  
Copyright © 1992 Vicon Industries Inc. All rights reserved.

Vicon part number 8006-7777-01-00  
Vicon and its logo are registered trademarks of Vicon Industries Inc.

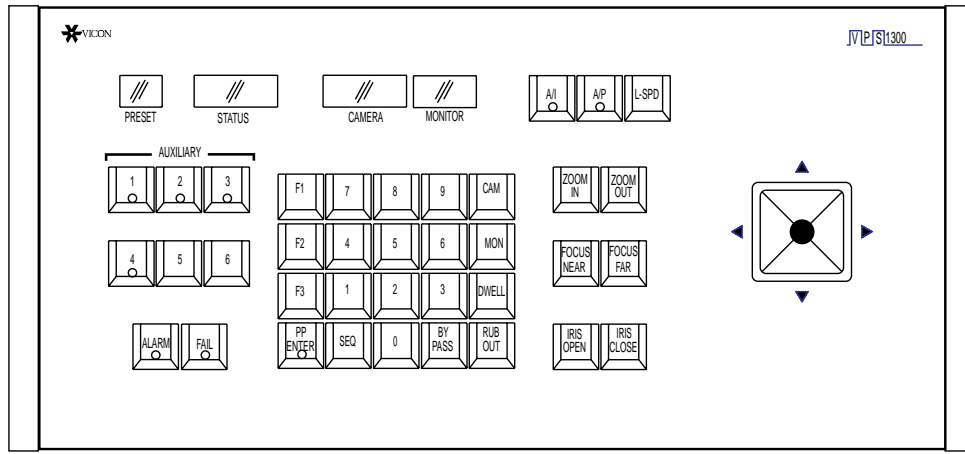

V1300X-DVC Desk-Top Keypad

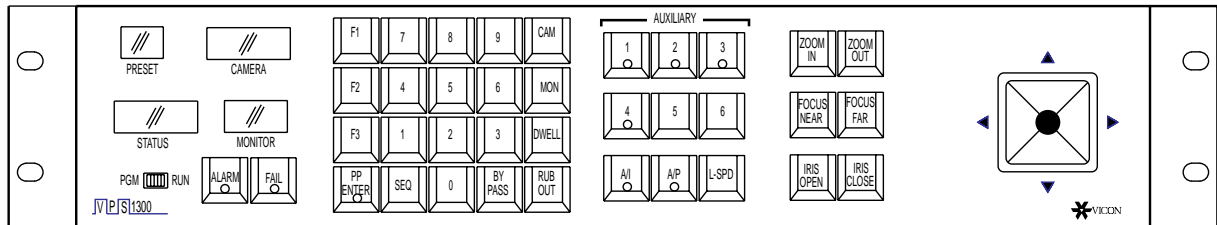

V1300X-RVC Rack-Mounted Keypad

**Figure 1**  
**V1300X Keypad Front Panels**

The keypad has several user-programmable macro keys. The macro function allows a series of multiple keystrokes to be programmed to one or two keys. The V1300X keypad has two single keystroke macro functions and 18 double keystroke macro functions. Each macro is programmable up to 256 keystrokes.

The keypads are compatible with the following Vicon products:

- a. VPS1300 Quantum-TSI Control System
- b. VPS1344 Quantum-TSI Control and Switching System
- c. VPS324 Transmitter/CPU
- d. VPS1200 Control System
- e. Matrix 44 High-Density Switcher with CPU
- f. V1300R Indoor/Outdoor Receiver
- g. V1200R Indoor/Outdoor Receiver
- h. V1200R-LM Multiple-Drive Indoor Receiver
- i. V15UVS Universal Omniscan with Receiver
- j. V1310RB Universal Receiver

**TABLE 1**  
**MODELS, PRODUCT CODES AND DESCRIPTIONS**

Model Number	Product Code	Description
V1300X-DVC	3987	Desk-top keypad, 115 VAC
	3987-01	Desk-top keypad, 230 VAC
V1300X-RVC	3990-10	Rack-mounted keypad, 115 VAC
	3990-11	Rack-mounted keypad, 230 VAC

The V1300X intelligent keypad uses an Intel 8031 micro-controller. The system supports three user-selectable modes of operation: the V1200X Keypad Mode, the V1300X Keypad Mode, and the Standalone Keypad Mode.

In the V1200X Keypad Mode, the V1300X keypad emulates all the features of a Vicon VPS1200 system keypad. It performs the standard pan-and-tilt, autopan, lens, autoiris, manual and sequential switching functions of the VPS1200 and VPS1300 control systems. This makes the V1300X keypad fully compatible with existing VPS1300, VPS1344, VPS1200, VPS324, and Matrix 44 systems. Refer to Figure 2, Sample Configuration of V1300X Keypad Used in V1200X or V1300X Keypad Mode.

In the V1300X Keypad Mode, the V1300X keypad is compatible with the VPS1300 CPU having CPU software revision level 2.0 or higher. The V1300X Keypad Mode is similar in operation to the V1200X mode (Figure 2), with a few additional features. In the V1300X Keypad Mode, the keypad handles the entire camera and monitor select sequence and pre-

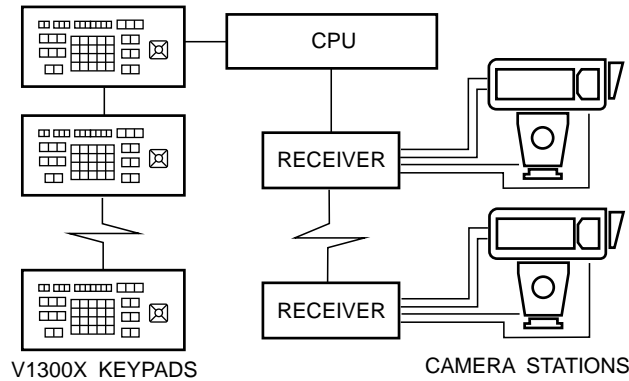

**Figure 2**  
**Sample Configuration of V1300X Keypad Used in V1200X or V1300X Keypad Mode**

set store/recall sequence. This minimizes communications overhead with the CPU. The keypads also have a greater address range (1-64). A new protocol allows for faster command execution in the V1300X Keypad Mode. Software for the V1300X Keypad Mode includes expanded variable speed operations. In this mode, the V1300X keypads may be used with V1200R and V1300R variable-speed receivers, the V1310RB universal receiver and the V15UVS Universal Omniscan with receiver.

In the Standalone Keypad Mode, the keypad can be used as a manual switching system capable of switching 255 cameras onto 128 monitors. In addition to manual switching, the keypad can perform sequential switching functions in Standalone Keypad Mode. All cameras can be set to sequence in ascending order on eight monitors. The keypad communicates directly with and fully controls the operation of up to 255 receivers. The V1300X keypad can also be used as a diagnostic device for Matrix 44 switchers and V1200R and V1300R receivers. A parallel communications port permits connection to and control of Matrix 44 video switchers. This facilitates on-site testing and repair of Matrix 44 card cages, V1300R receivers, and V1200R receivers. Up to 8 keypads can be used together in Standalone Keypad Mode. In the Standalone Keypad Mode, the V1300X keypad provides support for the V15UVS universal Omniscan with receiver. The keypad can also support V1344TDT-HD time/date/title boards by displaying a 3-digit camera ID for cameras displayed on a corresponding monitor. The title appears in the lower left corner of the screen. Refer to Figure 3, Sample Configuration of V1300X Keypad Used in Standalone Keypad Mode.

The V1300X keypad also offers several self-diagnostic tests. In diagnostic mode, the keypad tests itself for proper operation. Tests include:

- a. LEDs and status displays
- b. Serial and parallel communications

- c. Reset circuits
- d. Front panel and internal switches
- e. Memory ICs
- f. Analog-to-digital converter

The V1300X-RVC rack-mounted keypad mounts in a standard 19-inch EIA rack. The keypad may be tilted inside the rack at an angle of 12. This allows for easier viewing and operation of the front panel controls.

The keypads and receivers have signal conditioning circuits to provide reliable serial communication between remote units. Refer to Table 2 for Maximum Operating Distances Between Keypads Used in V1200X or V1300X Mode. When connecting multiple keypads in standalone mode, the keypad chain may be a maximum of 4000 feet long. There may be no more than 4000 feet between the first and last keypad in the chain.

**TABLE 2**  
**MAXIMUM OPERATING DISTANCES BETWEEN**  
**KEYPADS USED IN V1200X OR V1300X MODE**  
**SHIELDED, DUAL TWISTED-PAIR CABLE**

Cable Type	Maximum Distance ft (m)	Number of Cables Required*
Belden 9406	5000 (1500)	1
Belden 9402	5000 (1500)	1
Belden 8723	8000 (2400)	1
Belden 8162	15,000 (4600)	1
Belden 9729	15,000 (4600)	1
Belden 9182	25,000 (7600)	2

\*All cables in this table represent paired cable, except for Belden 9182. Belden 9182 is NOT a paired cable. Therefore, if Belden 9182 cable is used, 2 cables are required.

## TECHNICAL INFORMATION

### ELECTRICAL

Input Voltage: 115 V, 50/60 Hz.  
230 V, 50/60 Hz.

AC Input: V1300X-RVC: Standard line cord, three-conductor SV #18 AWG cable with grounding plug.  
V1300X-DVC: Rear panel 2-position terminal block, 10 VAC input from remote transformer.

Power Consumption: 20 W.

Heat Equivalent: Note: The following figures represent the conversion of 100% of the electrical energy to heat. Actual percentage of heat generated will be less and will vary from product to product. These figures are provided as an aid in determining the extent of cooling required for an installation.  
1.14 btu/min (0.29 cal/min).

Fuse: V1300X-DVC: 2 A, 3AG.  
V1300X-RVC, 115 VAC: 1/2 A, 3AG.  
V1300X-RVC, 230 VAC: 1/4 A, 3AG.

Circuit Boards: Main board.  
Front panel (top) board.

RS-485 Keypad Control: 9-pin (DB9) connector for RS-485 communications of multiple keypads used in standalone mode. The keypad chain (from the first keypad to the last keypad in the chain) may be a maximum of 4000 feet long.

RS-422 Keypad Control: RS-422 communications is used in V1200X and V1300X modes. Refer to Table 2 for maximum operating distances. 12-position terminal block for communications with transmitter/CPU or next remote keypad in line. Two leads differential RS-422 drive. Two leads differential RS-422 receive. Two leads shield ground.

Receiver Control: 12-position terminal block (same as above) for communications with remote receivers. Two leads differential RS-422 drive. Two leads differential RS-422 receive. Two leads shield ground. Refer to Table 2 for maximum operating distances.

Matrix Switcher Control: 34-pin ribbon cable connector for communications with Matrix 44 switcher.

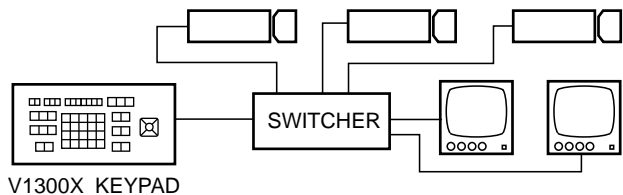

**Figure 3-a**  
**V1300X Keypad Used as Diagnostic Device**  
**for Matrix 44 Switcher**

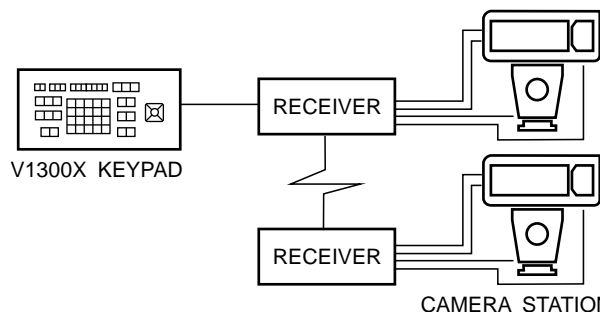

**Figure 3-b**  
**V1300X Keypad Used as Diagnostic Device**  
**for V1200R/V1300R Receiver**

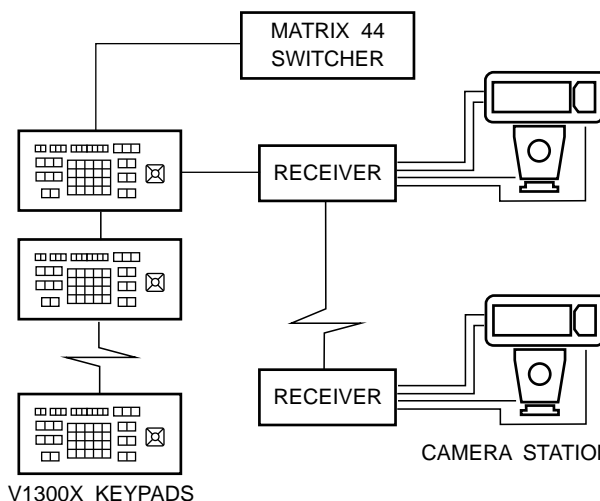

**Figure 3-c**  
**Multiple V1300X Keypads Used in Standalone**  
**Mode**

**Figure 3**  
**Sample Configuration of V1300X Keypad Used in Standalone**  
**Keypad Mode**

## CONTROLS

Numerical Keypad:	Camera/monitor system selection.
Camera Key:	Assigns selected camera to selected monitor.
Monitor Key:	For monitor selection enabling.
Dwell Key:	Accepts dwell time in camera display.
Rubout Key:	Used to correct data entries.
Bypass Key:	Causes selected camera to be bypassed during sequencing.
Sequencing Key:	Causes selected camera to be sequenced during sequencing.
Function Keys:	F1 used to change keypad operating mode. F2 and F3 used to program and execute macro functions.
Preset Position Enter Key:	Activates preset position shown in preset display.
Zoom In/Zoom Out Keys:	Manually zoom camera view closer or farther away. Momentary switch.
Focus Near/Focus Far Keys:	Manually focus camera view. Momentary switch.
Iris Open/Iris Close Keys:	Manually open or close current camera's iris. Momentary switch.
Alarm Key:	Acknowledges alarm circuits.
Fail Key:	Acknowledges and resets communication failure indication.
Auxiliary Keys:	Used to control auxiliary equipment. Four latching switches and two momentary switches.
Autoiris Key:	Engages or disengages automatic iris adjustment function.
Autopan Key:	Engages or disengages automatic panning function.
Lens Speed Key:	Toggles between two lens speeds (fast and slow).
Pan-and-Tilt Joystick:	Causes pan-and-tilt mechanism to

pan and tilt.

Program/Run Switch: Slide switch used to select keypad program mode or run mode (normal operation). Located on front panel of rack-mounted keypad and on rear panel of desk-top keypad.

## DISPLAYS

Preset:	2-character numeric display.
Status:	4-character alphanumeric display.
Camera:	4-character numeric display.
Monitor:	3-character numeric display.
Preset Position Enter:	LED.
Alarm:	LED.
Communication Failure:	LED.
Auxiliary On/off Status:	4 LEDs used with latching auxiliary functions.
Autoiris On/off Status:	LED.
Autopan On/off Status:	LED.

## MECHANICAL

Construction:	Zinc plated steel.
Finish:	Semi-gloss black finish.
Dimensions:	See Figure 4. V1300X-RVC Height: 3.5 in. (8.9 cm). Width: 19 in. (48.3 cm). Depth in rack (including rear panel connectors and fuse): 7.8 in. (19.8 cm). V1300X-DVC Height: 5.46 in. (13.9 cm). Width: 14.25 in. (36.2 cm). Depth: 7 in. (17.8 cm).
Weight:	V1300X-RVC: 12.2 lb (5.5 kg). V1300X-DVC: 7.9 lb (3.6 kg).

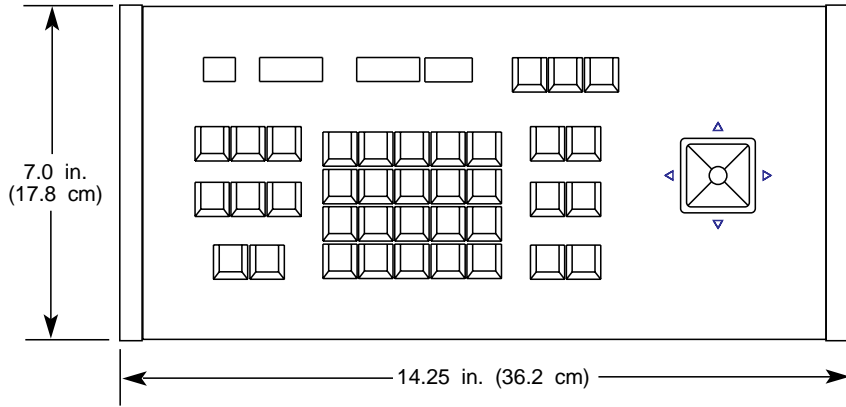
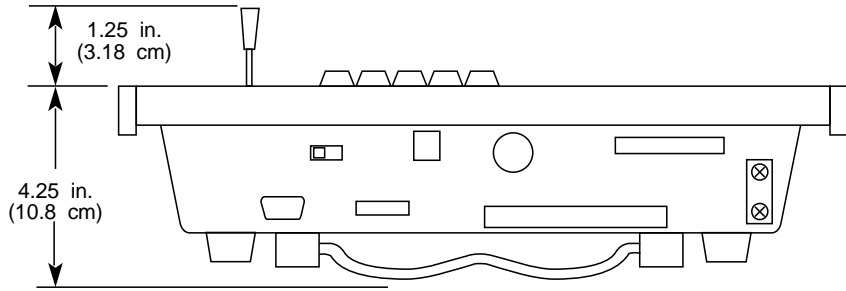

V1300X-DVC Desk-Top Keypad

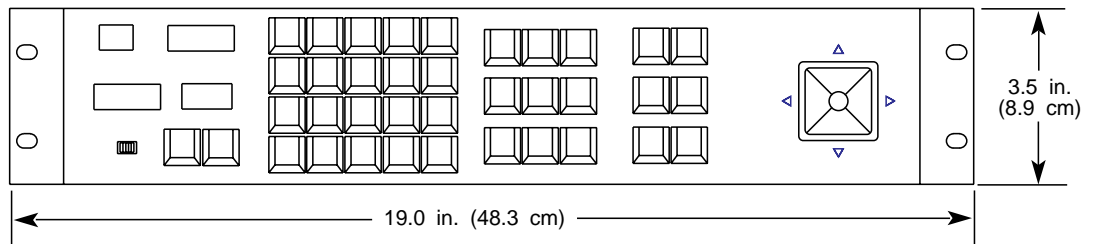
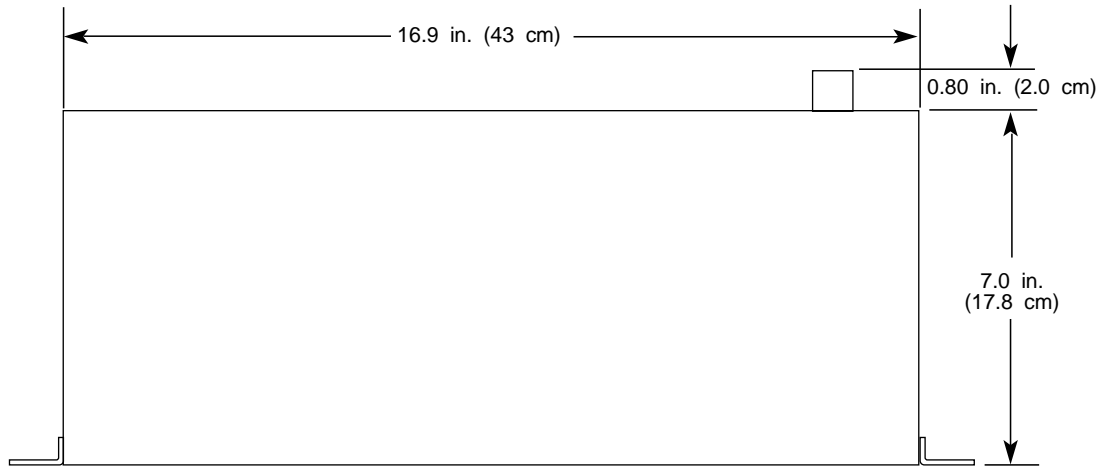

V1300X-RVC Rack-Mounted Keypad

**Figure 4**  
**Dimensions**